



Defence Research and
Development Canada

Recherche et développement
pour la défense Canada



Developing soft-kill capability for light armoured vehicles through battlefield simulations

*J.L. Rapanotti
DRDC Valcartier*

Defence R&D Canada – Valcartier

Technical Memorandum

DRDC Valcartier TM 2003-276

February 2007

Canada

Developing soft-kill capability for light armoured vehicles through battlefield simulations

J.L. Rapanotti
DRDC Valcartier

Defence R & D – Valcartier

Technical Memorandum

DRDC Valcartier TM 2003–276

February 2007

Author

J.L. Rapanotti

Approved by

Philip Twardawa
Head, Electro-Optical Warfare

Approved for release by

Gilles Bérubé
Chief Scientist

This study is in direct support of the major project FAVS-TD (Future Armoured Vehicle Systems - Technology Demonstrator) and minor project DAS for LAV as described in work unit 2fi16.

© Her Majesty the Queen as represented by the Minister of National Defence, 2007

© Sa majesté la reine, représentée par le ministre de la Défense nationale, 2007

Abstract

Light Armoured Vehicles (LAVs) are being developed to meet the modern requirements of rapid deployment and operations other than war. To achieve these requirements, passive armour is minimized and survivability depends more on a soft-kill capacity including sensors, computers, countermeasures and communications to detect and avoid threats. Sensors for these soft-kill systems are passive, to avoid being detected, and therefore can be used to detect threats at much longer ranges. Battlefield obscuration strategies, optimized for Main Battle Tanks in traditional high intensity conflicts, are inadequate when applied to LAVs. LAVs are vulnerable to many threats and sufficiently different in design, capability and battlefield environment to benefit significantly from new strategies. Factors influencing this requirement include: i) the development of sensors with increasing accuracy and precision, ii) the need to minimize obscurant interference with vehicle sensors and other countermeasures, including active armour and explosive reactive armour, iii) the need to develop hemispherical obscurant coverage extending into the millimetre wave range, iv) grenades are needed to better match the increased tempo from greater vehicle speed, mobility and turret slew rate, v) the automatic configuration and selection of grenade burst patterns based on on-board processing and vehicle networks.

Spectral coverage in the visible to long-wave infrared regions is adequate, but trends in missile design are leading to the development of hybrid seekers, including laser designating, MMW seeking and imaging-infrared seeking capability accelerated by MEMS technology. With increased tempo, the time needed to achieve full obscuration becomes critical. Dazzling of a detected threat can be used to disrupt aiming and firing a second missile until full obscuration is achieved. Dazzling can also be used with the laser-illumination detection of optical systems. A generic threat response, based on dazzling and visible/IR/MMW grenades is preferred because of the large number of possible threats and the difficulty in developing practical identification strategies.

New dazzling and obscuration strategies, based on extensive knowledge acquired through field trials, will be analyzed and developed using ModSAF. These new strategies and the approach used to develop them will be discussed in the memorandum. The impact these technologies will have on LAV vetronics is also discussed in Annex A.

Résumé

Des véhicules à blindage léger (VBL) sont développés pour répondre aux exigences modernes de déploiement rapide et d'opérations autres que dans un contexte de guerre. Pour réaliser ces conditions, le blindage passif est réduit au minimum et la survie dépend davantage de la capacité de défense passive "soft-kill" comprenant des systèmes de détection des ordinateurs, des contre-mesures et des communications afin de détecter et d'éviter les menaces. Les systèmes de détection sont passifs et peuvent donc être employés pour détecter les menaces à des distances beaucoup plus grandes. Les stratégies d'obscurcissement de champ de bataille, optimisées pour les chars d'assaut lors de conflits de grande intensité, est insatisfaisante une fois appliquées au VBL. Les VBL sont vulnérables à beaucoup de menaces, mais ils sont suffisamment différents de par leur conception, leurs capacités et l'environnement du champ de bataille pour bénéficier de manière significative des nouvelles stratégies. Les facteurs influençant cette condition incluent: i) le développement de systèmes de détection avec l'augmentation de l'exactitude et de la précision, ii) le besoin de réduire au minimum l'interférence des obscurcissants avec les systèmes de détection du véhicule et d'autres contre-mesures, y compris le blindage actif et le blindage réactif explosif, iii) le besoin de développer l'obscurcissement hémisphérique pour des fréquences millimétriques, iv) des grenades nécessaires pour améliorer l'harmonie avec le tempo opérationnel du véhicule qui possède plus de rapidité, de mobilité ainsi que la vitesse angulaire de la tourelle, v) d'une configuration et d'un choix automatique des modèles de dispersion de grenades basés sur le traitement interne des données et sur les réseaux de traitement et de véhicules.

La couverture spectrale dans le domaine des fréquences visibles et dans les régions infrarouges est adéquate, mais les tendances dans la conception des missiles mènent le développement des têtes chercheuses hybrides comprenant le désignateur laser, les têtes chercheuses MMW avec les possibilités d'imagerie infrarouge accélérée par la technologie MEMS. Avec un tempo accru, le temps nécessaire pour réaliser le plein obscurcissement devient critique. L'éblouissement d'une menace détectée peut être employé pour perturber la visée et le lancement d'un deuxième missile jusqu'à ce que le plein obscurcissement soit réalisé. L'éblouissement laser peut également être employé par un illuminateur pour la détection des systèmes optiques. Une réponse générique de menace, basée sur l'éblouissement laser et des grenades, efficace dans le visible/IR/MMW, est préférable en raison du grand nombre de menaces possibles et de la difficulté de développer des stratégies d'identification pratiques.

De nouvelles stratégies d'éblouissement et d'obscurcissement, basées sur la connaissance étendue acquise par des essais en service réel, seront analysées et développées en utilisant ModSAF. Ces nouvelles stratégies et l'approche employée pour les développer seront discutées dans ce mémorandum. L'impact de ces technologies sur le système vétronique est également discuté à l'annexe A.

Executive summary

Soft-kill systems rely on long-range passive sensors, obscurants and countermanoeuvring to avoid threats. Based on technology trends, a 2010 system based largely on off-the-shelf components can be configured as follows:

1. Sensors

- (a) **Staring arrays** providing hemispherical mid-infrared coverage with a resolution of 4096×4096 pixels per corner of the main turret and operating at a 60 Hz frame rate with
- (b) **Scanning arrays** mounted in a mini-turret with a slew rate of $750^\circ/\text{s}$ including
 - mid-infrared coverage, based on an array of 1024×1024 pixels with a field of view of $2.5^\circ \times 2.5^\circ$ and a 60 Hz frame rate,
 - a laser illuminator and range-gated camera based on a near-infrared coverage, based on an array of 1024×1024 pixels with a field of view of $0.5^\circ \times 0.5^\circ$ at 60 Hz.

2. Countermeasures including:

- (a) **Obscuration** based on passive smoke grenades using metal-flake and chaff providing hemispherical coverage extended with laser dazzling to fill in the 1.5 s gap until full obscuration is achieved,
- (b) **Countermanoeuvring** the vehicle with input from vetronics sensors and robotic automation to reduce crew workload.

The integration of various technologies into a Defensive Aids Suite (DAS) can be designed and analyzed by combining field trials and laboratory data with modelling and simulation. ModSAF (Modular Semi-Automated Forces), a war-gaming simulator is used to construct a virtual battlefield based on models from three sources, including: models of technology and natural phenomena from scientists and engineers, tactics and doctrine from the military and detailed scenarios from operations research. This approach ensures the modelling of processes known to be important regardless of the level of information available about the system. Survivability of DAS-equipped vehicles based on future and foreign technology can be investigated by ModSAF and assessed relative to a test vehicle. A system can be modelled phenomenologically until more information is available.

Vehicle performance is affected by communication with other vehicles and other battlefield assets. Networking technology developed by SUN Microsystems to develop a rapid response subnet was also investigated.

J.L. Rapanotti, 2007, "Developing soft-kill capability for light armoured vehicles through battlefield simulations," DRDC Valcartier TM-2003-276, Defence R&D Canada.

Sommaire

Les systèmes “soft-kill” dépendent de la détection passive à longue portée ainsi que des dispositifs obscurcissants et des contre-mesures pour éviter les menaces. Selon les tendances technologiques prévues pour l’an 2010, un tel système de composantes disponibles directement des manufacturiers pourrait être configuré comme suit:

1. Système de capteurs

- (a) **Capteur fixe** fournissant une couverture hémisphérique dans l’infrarouge moyen, 4096×4096 pixels par coin de la tourelle principale avec une fréquence d’échantillonnage de 60 Hz
- (b) **Balayage de capteur** monté sur une mini-tourelle avec une vitesse angulaire de $750^\circ/s$,
 - Couverture dans l’infrarouge moyen, 1024×1024 pixels avec un champ de vision de $2,5^\circ \times 2,5^\circ$ à 60 Hz
 - Un illuminateur laser et une caméra à imagerie active à crénelage en distance dans le proche infrarouge, 1024×1024 pixels avec un champ de vision de $0,5^\circ \times 0,5^\circ$ à 60 Hz

2. Contre-mesure incluant:

- (a) **L’obscurcissement** basé sur des grenades fumigènes passives utilisant des flocons de métal et des paillettes pour une couverture hémisphérique, l’éblouissement laser peut également être utilisé sans risque contre le personnel pour combler une lacune de 1,5 s de temps nécessaire pour obtenir le plein obscurcissement.
- (b) **Manœuvre évasive du véhicule** avec des données transmises par les systèmes de détection reliés au système vétroniques et l’automatisation robotique.

L’intégration des technologies multiples afin de former une suite d’aides à la défense (SAD) peut être conçue et analysée avec une combinaison d’essais réels et des données en laboratoire à l’aide de la modélisation et de la simulation. ModSAF (Modular Semi-Automated Forces) est utilisé pour recréer un champ de bataille virtuel et, à l’aide de scénarios sous forme de fichiers, des vignettes peuvent être définies et exécutées à partir de trois sources distinctes. Ces contributions incluent : la modélisation de la technologie et des phénomènes naturels par les scientifiques et les ingénieurs, des tactiques et doctrines du personnel militaire ainsi que des analyses détaillées de la recherche opérationnelle. Cette approche assure que le procédé de modélisation soit complet peu importe l’information disponible concernant le système à modéliser. La surviabilité d’un véhicule équipé d’une SAD fondée sur des technologies futures et étrangères peut être examinée à l’aide de ModSAF et expérimentée sur un véhicule test. Un système peut être modélisé basé sur l’observation du phénomène. Le modèle sera corrigé une fois que plus d’informations soient disponibles.

J.L. Rapanotti, 2007, “Developing soft-kill capability for light armoured vehicles through battlefield simulations,” DRDC Valcartier TM-2003–276, Defence R&D Canada.

Table of contents

Abstract	i
Résumé	ii
Executive summary	iii
Sommaire	iv
Table of contents	v
List of figures	vi
List of tables	vii
Acknowledgements	viii
1. Introduction	1
2. Developing soft-kill capacity	2
2.1 Modelling and simulation	3
2.2 Threat detection	7
2.3 Obscuration and dazzling strategies	10
2.3.1 Launcher calculations	12
2.3.2 Automated threat responses	12
2.3.3 Soft-kill system response	13
3. Concluding remarks	19
4. References	21
Annex A: Vetrionics and networking	23
Distribution list	31

List of figures

Figure 1. Layers of survivability.....	2
Figure 2. ModSAF development.	4
Figure 3. Incremental evolution of DAS technology.....	5
Figure 4. General DAS system.	6
Figure 5. LAV optical system.....	8
Figure 6. Typical grenade-burst pattern for a main battle tank.....	14
Figure 7. Solution of the launcher equation for various launcher and vehicle angles.....	15
Figure 8. Typical grenade-burst pattern based on new lav requirements.	15
Figure 9. Dazzling and grenade-burst patterns for slowing, stopping and backing up.	16
Figure 10. Dazzling and grenade-burst patterns for a moving vehicle.....	17
Figure 11. DAS obscuration and dazzling countermeasures.	17
Figure 12. Detection and response to automatic weapon fire.	18
Figure A1. Turret and sensor pod configuration.....	25

List of tables

Table 1. Threat missiles classified by guidance or communications system.....	3
Table 2. Passive staring/scanning optics performance.....	9
Table 3. Main battle tank and light armoured vehicle grenade system parameters	14
Table A1. Current computer and communications characteristics.....	23
Table A2. Future computer and communications characteristics.....	24

Acknowledgements

The author would like to thank Mr. Paul Brière and Dr. Gilles Roy for their useful advice and discussions on the subject of smoke grenade design and infrared obscurants.

1. Introduction

Modern weapons have reduced the traditional effectiveness of passive armour on land vehicles. The LAV designed to survive these modern threats relies less on passive armour and more on sensors, computers and countermeasures. Examples of these threats include portable missiles with multiple shape-charge warheads penetrating any thickness of armour and both sensor-fuzed munitions and top-attack missiles penetrating the vulnerable top of the turret. Survivability for modern vehicles begins with detection avoidance by various means, including camouflage and vehicle signature reduction. Once detected, survivability is increased by early threat detection and countermeasures to either defeat the threat directly or reduce the effectiveness of the guidance system. This last aspect of survivability through threat avoidance is considered by this study. Additional requirements, such as mission configurability and upgrading over a long service life, can be met with a modular design. A modular approach to developing and maintaining survivability of the vehicle based on identified technological trends is also discussed.

To better understand, evaluate and develop the DAS, a war-gaming simulator is being developed to carry out realistic evaluations in a context useful and relevant to the military. ModSAF (Modular Semi-Automated Forces) is used to construct the virtual battlefield, (Refs.[1-3]), for evaluation of light armoured vehicles. Any weapon system can be improved by better materials and design. ModSAF can be used long before the system is fielded to develop new tactics and doctrine. Crew familiarization and training can be undertaken, initially, on stand-alone systems and progress through to vehicle simulators. In future vehicles, embedded simulators can be used to model the environment surrounding the vehicle, including terrain, atmosphere, threats and other vehicles.

Modelling physical systems in ModSAF is not new. Terrain features are represented in sufficient detail to study vehicle mobility, detection, defilade and other practical manoeuvres. Atmospheric phenomena are modelled to produce accurate effects of attenuation over distance, scattering by smoke and dust and incident sunlight. Spectral effects in the atmosphere, such as propagation of artificial source in the solar-blind ultraviolet regime, natural effects such as solar glint and complicated, variable signatures from missiles are also modelled.

The combination of increasing computer power at low cost and the robustness of ModSAF can also be used to represent vehicles more realistically and in more realistic environments and evaluated more thoroughly than previously possible before final field evaluations. The DAS and LAV configurations being evaluated are described in more detail below.

The sections below will describe the factors influencing vehicle survivability and how dazzling and obscuration will be used to counter potential threats. Some of the aspects of modelling a counterfire improvement based on a high-speed missile and a typical Main Battle Tank (MBT) countermeasure are also discussed below.

2. Developing soft-kill capacity

Modern weapons have reduced the effectiveness of passive armour leading to the development of light armoured vehicles and the capability of rapid deployment to discontinuous battlefields. The traditional role of passive armour is being enhanced by signature management and defensive aids suites as shown in Figure 1. As indicated by the first layer, vehicle survivability can be improved by reducing the size and silhouette of the vehicle and through signature management or the overall reduction to background levels of visible and infrared signatures, radar cross-section, and electronic, acoustic, and magnetic signatures. Once the vehicle has been detected, the second layer of technology, threat avoidance, becomes important.

The implementation of threat avoidance relies on a system of sensors, processors and countermeasures. The trends in these technologies affect the level of protection available in future vehicle designs. The trends in the computer and communications technology needed to integrate these components on the vehicle were also studied and are presented in Annex A.

As the challenges of hit avoidance, including short timelines and numerous threats, are addressed, the solutions will lead to greater weapon precision and increased tempo on the battlefield.

Among the many threats to land vehicles, a list of 89 missiles was compiled, (Ref. 3 in Table 1) according to the guidance and communication links used, (Ref. 4).

In this list, virtually all of the missiles have an operator in the loop leading to the possibility of using a combination of dazzling and obscurants to disrupt the aiming sequence. An effective

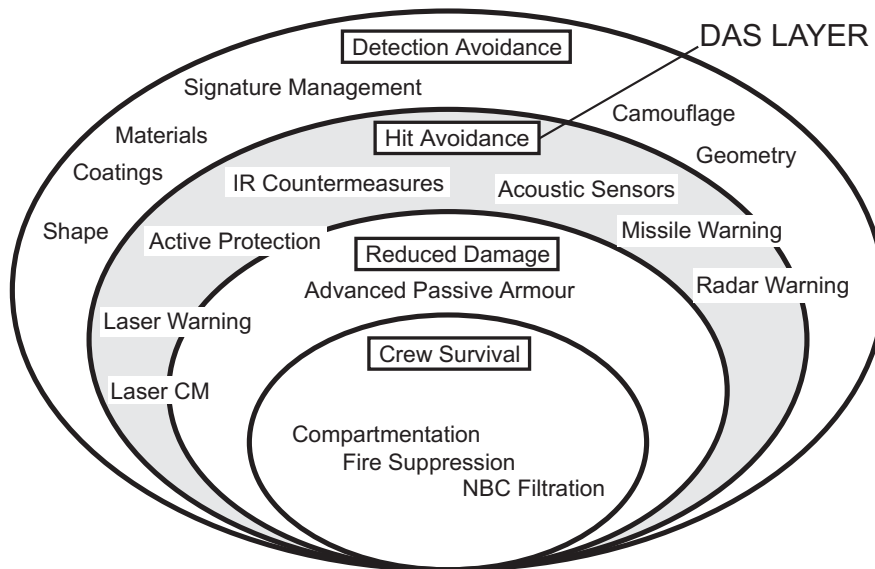

Figure 1. Layers of survivability. With the reduction of passive armour, greater emphasis is on detection avoidance and on, the DAS layer, hit avoidance.

Table 1. Threat missiles classified by guidance or communications system

Number	Missile Type, Ref. [4]
41	Semi-Automatic Command to Line of Sight (SACLOS)
16	Laser Beam Rider (LBR)
11	Manual Command to Line of Sight (MCLOS)
8	Fibre-optic guided missiles (FOGM)
7	Imaging Infrared
6	Laser and millimetric wave designation, including Semi-Active Homing
3	Laser based guidance or communications link
2	Automatic Command to Line of Sight (ACLOS)
1	Radio Frequency Homing
89/95	Total missiles/Total configurations

DAS could be based on threat detection and countermeasures, including dazzling, obscurants, counterfire and evasive manoeuvres. This “soft-kill” solution can be effective since the large number and variety of threat missiles can make identification, and therefore countermeasure selection, difficult. This difficulty can be overcome with a “hard-kill” solution, which will physically destroy the missile.

2.1 Modelling and simulation

A Model-Test-Model cycle is difficult to establish, at the moment, for a variety of reasons, including lack of information about foreign systems and incomplete models of the sensor and countermeasure environment. As shown in Figure 2, a continuous cycle can be established using field trials and experimental data to develop models and simulations. Ideally, models should be based on physical principles, but when this is impractical, systems can still be analyzed phenomenologically. Both approaches can be implemented in ModSAF. ModSAF (Modular Semi-Automated Forces) was developed for training and doctrine development and provides a capability to define and control entities on a simulated battlefield. It is a model of the dynamic behaviour of simulated units, their component vehicles and weapons systems with sufficient realism for training and combat development. ModSAF simulates an extensive list of entities including fixed and rotary wing aircraft, ground vehicles, dismounted infantry, and additional special models such as howitzers, mortars, minefields, and environmental effects. The behaviour of the simulated entities can be scripted so they can move, fire, sense, communicate and react without operator intervention. The entities, can interact with each other as well as manned simulators, over a network supported by Distributed Interactive Simulation. Operating over a network is also useful in maintaining a necessary level of security.

These basic features in ModSAF are sufficient to define the participation of three groups of workers and implement their requirements free from mutual interference. To gain general acceptance, ModSAF development must meet the requirements of the scientists and engineers

who develop the technology, the operations research community and the military developing tactics and doctrine. MATLAB[®], which is designed for quick-prototyping and code generation, can be used for ModSAF development. MATLAB modelling can also be used to share information with contractors and other researchers. As shown in Figure 2, an important application of ModSAF is the generation of a battlefield environment for Man-In-the-Loop simulators. The MIL simulators are critical in the development of a suitable Man-Machine-Interface for the DAS.

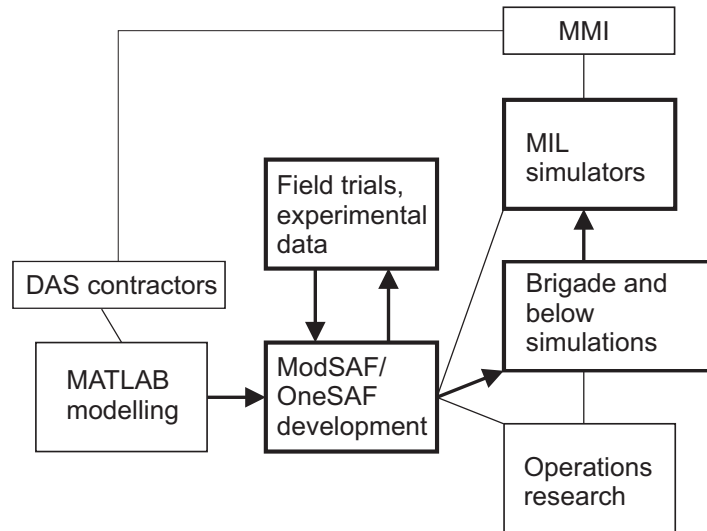

Figure 2. The four aspects of ModSAF development are shown. MATLAB is used as a quick-prototyping tool generating, transferable models and code usable by ModSAF. There is a tight loop between field evaluations and ModSAF development used to design DAS prototypes and plan future trials. Larger battles are carried out in simulation labs where new tactics and doctrine are developed. ModSAF is also used to provide the battlefield around Man-In-the-Loop simulators. From the simulators, the man-machine interface and vehicle operating systems are developed.

Rapid deployment of the vehicle to a wide range of possible missions and low cost upgrading plays a significant role in the design of the DAS. Some desirable DAS characteristics include a

1. **fitted for, but not fitted with**, approach providing a quick response at low cost implies designing the vehicles for equipment upgrades according to the mission requirements without needing to purchase for the entire fleet,
2. **modularity** including minimizing the interference among subsystems, which can complicate an upgrade and incremental upgrades of best of breed technology of a federation of modules instead of an integration of fused sensors,
3. **mission configurability** relying, for example, on the Galix grenade system that offers a wide range of capability from CS gas and stun grenades for peacekeeping to obscurants and fragmentation grenades for higher intensity warfare and a
4. **plug and play capability** facilitating fast upgrading and replacement, and

5. **general purpose solution** providing acceptable performance for a wide range of requirements,
6. **robustness** avoiding catastrophic failure of the DAS with sensors based on complementary technologies and data fusion to improve performance and to replace lost sensors.

This level of readiness also facilitates rapid acquisition of up-to-date technology and further facilitates rapid deployment.

The DAS should be a federated, modular and mission configurable system, interfaced to the vehicle bus for access to other systems such as the Fire Control System. To keep the cost as low as possible the DAS based on more mature technology first and because of the rapidly evolving nature of technology modified through 5-year upgrades. DAS evolution is represented in Figure 3, could be carried out as described in the chapters below. The 2010 and 2015 vehicles would be designed to operate in a network, Ref. [5].

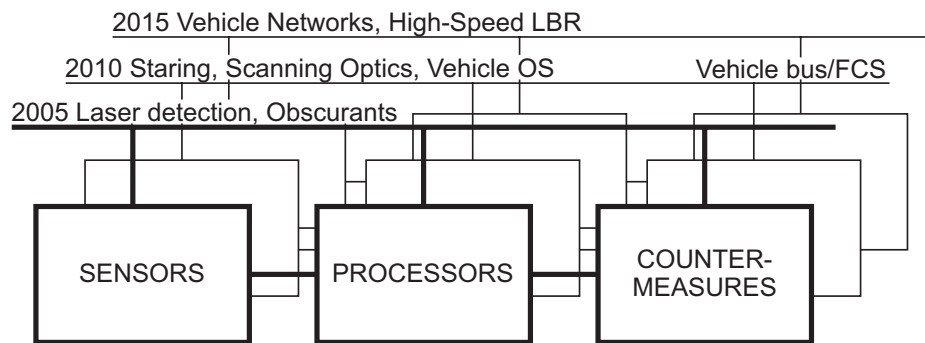
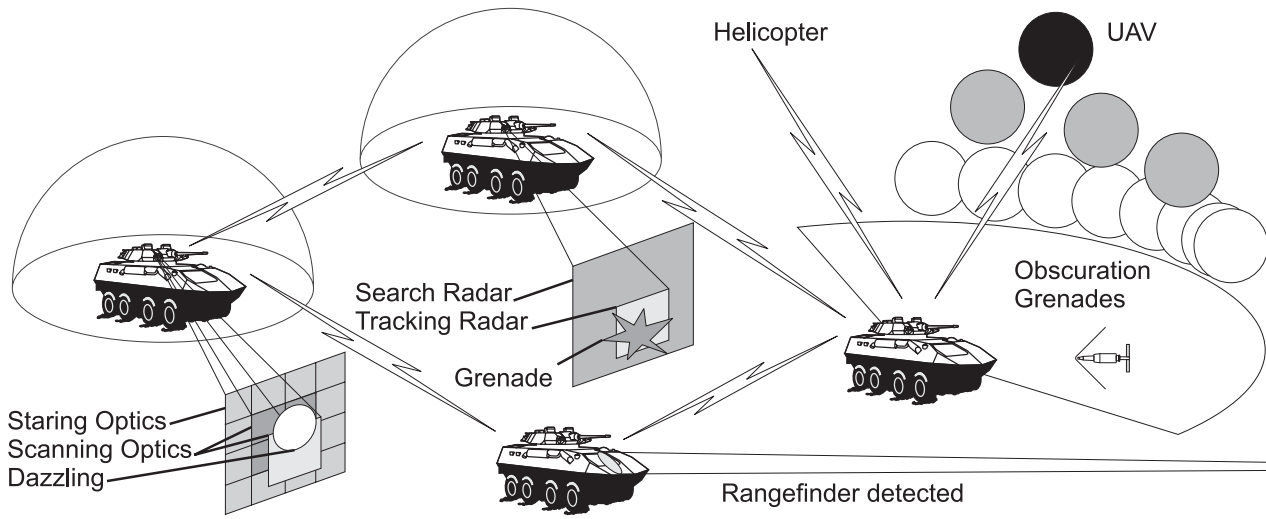

Figure 3. The rate at which computer and sensor technologies are developed justifies 5 year upgrade increments. The more mature technology is implemented beginning with laser-aided threat detection and visible/IR/MMW obscurants. Improved situational awareness, detection and identification is possible with staring and scanning optics. An operating system is needed to interface the vehicle bus and fire control system with the DAS for efficient use of LAV resources. By 2015, improved survivability can be achieved through vehicle networks and increased operational tempo and firepower with high-speed missiles. The 2010 and 2015 vehicles would be designed to operate in a network.

2010 Light Armoured Vehicle: The 2010 DAS includes automatic, semi-automatic and manual response of counterfire, countermanoeuvres and obscurants. The optics used for detection and dazzling are shown in Figure 5. Infrared focal-plane arrays provide a hemispheric coverage for increased situational awareness

1. Sensors

- (a) **Staring arrays** providing hemispherical mid-infrared coverage with a resolution of 4096×4096 pixels per corner of the main turret and operating at a 60 Hz frame rate with



SINGLE LAV	VEHICLE NETWORK
HARLID DETECTS RANGEFINDER AT 1.8 km	HARLID DETECTS RANGEFINDER AT 1.8 km
COMMANDER CHOOSES FROM	UAV CORRECTS RANGE TO 1.853 km
APFSDS 150 ROUNDS	COMMANDER CHOOSES FROM
HEI 60 ROUNDS	APFSDS 600 ROUNDS
	ROCKETS 38
	HEI 240 ROUNDS
APFSDS CHOSEN AND FIRED	APFSDS CHOSEN AND FIRED

Figure 4. The four basic components of a DAS, as shown, including: hard-kill, (top), and soft-kill systems, acoustic threat detection, (supersonic round, far right), and detection of active targeting systems, (rangefinder, bottom). Automated short-range communications will transform single LAVs into vehicle networks interacting with other available platforms. The soft-kill subsystem consists of the passive optics, (far left), and smoke grenades, (far right).

(b) **Scanning arrays** mounted in a mini-turret with a slew rate of 750°/s, including

- mid-infrared coverage, based on an array of 1024×1024 pixels with a field of view of 2.5°×2.5° and a 60 Hz frame rate,
- a laser illuminator and range-gated camera based on a near-infrared coverage, based on an array of 1024 × 1024 pixels with a field of view of 0.5°×0.5° at 60 Hz

2. **Countermeasures** including:

- (a) **Obscuration** based on passive smoke grenades using metal-flake and chaff providing hemispherical coverage extended with laser dazzling to fill in the 1.5 s gap until full obscuration is achieved,
- (b) **Countermanoeuvring** the vehicle, once the smoke screen is in place, with input from vtronics sensors and robotic automation to reduce crew workload.

Countermeasures begin with dazzling until full obscuration is achieved to reduce targeting efficiency. A typical pattern for the IR scanning array is also shown in Figure 5. Superimposed on the frames is the trace of the laser illuminator. The horizontal scan is 135° followed by a vertical angular displacement of 15° and retracement. The 15° vertical scan detects threats on other than nap-of-the-earth or high angle-of-attack trajectories. Horizontal scanning can be accompanied by dazzling to improve detection by retroreflection or to disrupt aiming. Upon detecting a threat, active range-gated scanning can be used to improve contrast and defeat camouflage. The total scan time of 1.9 s is comparable to the duration of the boost motors on many missiles and rockets. Using onboard sensors, the near-IR array is aimed at a virtual 5 km distance to maximize threat detection while scanning.

High Availability (HA) principles are being used to develop reliable computer systems, (Refs. [6 and 8]), in critical applications and will influence the development of vehicle networks and DAS, Ref. [5]. The high level of reliability and transparency to the user will make the DAS much easier to accept. High Availability technologies available through JiniTM include alternate or redundant paths to sensors, dynamic reconfiguration of the System comprising dynamic attachment and detachment and “hot pluggable” and “hot swappable” components. The operating system is critical in the development of High Availability systems. Both VxWorks[®] AE, and LynxOS[®] have many of these features. VxWorks AE is described as a real-time operating system with HA features including: Reliability, Availability, Serviceability, and Security (RASS). These networking concepts are discussed in more detail in Annex A.

2.2 Threat detection

Detection is maximized by optical sensitivity in the infrared range, contrast between the threat and background and dimensions of the image registered on the array. The combustion of propellants and gunpowder produces high-temperature mixtures of carbon dioxide, water and particulates detectable in the infrared range. The performance of the passive sensors can be estimated by from the dimensions of the radiance image at various threat ranges.

Countermeasures can then be determined from the available reaction time as a function of the threat velocity and range. The detection ranges for the WFOV and NFOV optics, in Figure 5, for various threats are shown in Table 2. In a typical scenario, the WFOV optics detect a short duration flash and hand off to the NFOV array. With a mini-turret slew rate of $750^\circ/\text{s}$, NFOV imaging begins within 0.25 s. Depending on algorithm effectiveness, smoke grenades can be launched to provide full obscuration within 2 s of the initial detection, (Ref. [9]). The NFOV optics can also hand off to the LI/RG camera which operates at a higher resolution. Active imaging can be used to improve detection and classification of both the threat and the target platform.

Based on the results in Table 2, both of the laser beam-rider missiles are difficult to detect at maximum range, suggesting that detection of the guidance laser source as well may be useful. The WFOV staring system detects missiles at ranges exceeding 300 m. Rocket propelled grenades can be detected and tracked but because of the short range of operation have to be stopped by either passive armour, explosive reactive armour or a hard-kill system. Gun rounds can also be detected but invariably have to be stopped by the hard-kill system. The debris from the destruction of these rounds requires the additional protection of appliqué armour. The

125 mm APFSDS is a kinetic energy weapon and is virtually impossible to stop with the countermeasures described here. Finally, artillery rounds can also be detected and tracked despite the absence of a missile plume.

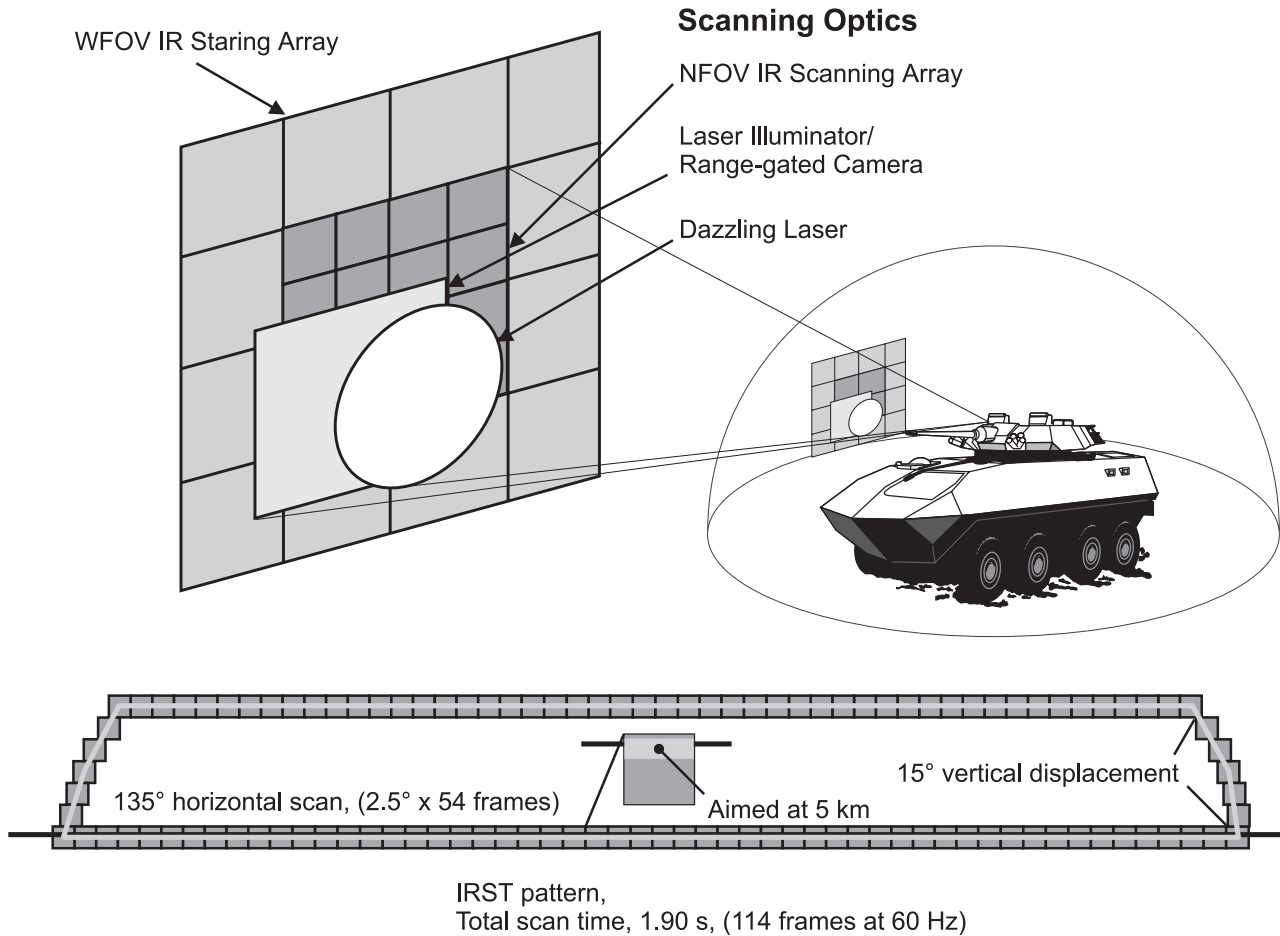

Figure 5. The sensors of the soft-kill subsystem are shown including the staring arrays mounted on the main turret and the mini-turret optics. Improved resolution, and detection, is possible by aiming or scanning with the mini-turret optics, (bottom). The LI/RG camera is aimed at a virtual 5 km distance, to maximize threat detection of long-range weapons, during the ground scan. Laser dazzling is used with smoke grenades to defeat threat targeting systems.

Table 2. Passive staring/scanning optics performance

Anti-Armour Threats	IR WFOV	IR NFOV	LI/RG Camera		Threat Variables		
Threat, caliber	Distance, m	Distance, m	Threat, ^A pixels	Target, ^B pixels	Dimensions, m	Range, m	Velocity, ^C m/s
M-712, LSAH, 155 mm	400	3600	1.3	25 × 20	0.155 dia.	14000	255
AT-5, 135 mm	4770 / 860 ^D	7740	54 × 10	90 × 30	1.83 × 0.33	4000	175
AT-11, LBR, 125 mm	1640 / 330	3050	15 × 3	70 × 23	0.63 × 0.13	5000	255
AT-13, 130 mm	3500 / 600	5400	105 × 18	235 × 78	1.34 × 0.23	1500	170
AT-14, LBR, 152 mm	3180 / 400	3750	26 × 4	64 × 21	1.22 × 0.16	5500	210
TOW 2A, 149 mm	9410 / 1360	12200	113 × 16	94 × 31	3.61 × 0.52	3750	235
RPG-7, 80 mm	470	4200	42 × 42	234 × 187	0.18 dia.	500	255
RPG-16, 58.3 mm	470	4200	26 × 26	146 × 117	0.18 dia.	800	300
RPG-18, 64 mm	8600 ^E	1500 ^F	37 × 37	586 × 469	3.3 dia.	200	95
Gun, 125 mm, HEAT	17200	3050	16	90 × 30	6.6 dia.	4000	775
Gun, 125 mm, APFSDS	17200	700	4	118 × 60	6.6 dia.	2000	1450
Gun, 30 mm, AP	5480	700	4	118 × 60	2.1 dia.	2000 ^G	815
Gun, 30 mm, APDS	5480	340	0.8	118 × 60	2.1 dia.	2000	815

^A The dimensions of the threat in pixels at the maximum range on the right.

^B The dimensions of the "RED" target at the maximum range. The M-712 threat is a 3 m × 2 m vehicle, for the missiles and gun rounds a 3 m × 1 m turret, and an individual fighter, 1 m × 0.8 m, for the rest.

^C An average velocity estimated to be 85% of the boost or muzzle velocity.

^D At 4770 m the image is one pixel wide, but not until 860 m is it one pixel high, or 6 × 1 total. An efficient detection algorithm will detect the threat at about 4700 m, a less effective one at 900 m.

^E Based on blast detection.

^F Based on projectile detection.

^G The next two ranges are reduced from 4000 m to a more useful 2000 m.

2.3 Obscuration and dazzling strategies

Smoke grenades improve the survivability of a fighting vehicle traveling between defilade points by controlling the immediate environment and interfering directly with targeting and guidance. Battlefield obscuration strategies, optimized for Main Battle Tanks in traditional high intensity conflicts, are inadequate when applied to Light Armoured Vehicles. LAVs are vulnerable to many threats and sufficiently different in design, capability and battlefield environment to benefit significantly from new strategies. Factors influencing this requirement include: i) the development of LAV sensors with increasing accuracy and precision, ii) the need to minimize obscurant interference with LAV sensors and other countermeasures, including active armour and explosive reactive armour, iii) the need to develop hemispherical obscurant coverage extending into the millimetre wave range, iv) grenades are needed to better match the increased tempo from greater vehicle speed, mobility and turret slew rate, v) the capability of automatic configuration and selection of grenade burst patterns based on on-board processing and vehicle networks. These factors influencing the use of obscurants with LAVs are discussed in more detail below.

Increasing Sensor Accuracy and Precision New generations of sensors are being developed providing greater levels of situation awareness. These performance improvements are being accelerated by MEMS technology to produce even smaller, hybrid systems with new properties based on combined characteristics. An example of a new detector is the laser detecting HARLID. With an angular resolution of $\pm 1^\circ$, it is a significant improvement over existing systems, (Ref. [10]). A current laser warning receiver with a typical resolution 22.5° can detect a threat but not provide the position with sufficient accuracy. The only reasonable response from the crew is to launch smoke grenades and back the vehicle away from the threat. Based on the HARLID technology, a laser threat is detected in less than 1 msec, but with a resolution $\pm 1^\circ$ not accurately enough to position the main gun. Combined with an IR staring array, the stream of pixels corresponding to the laser source can be analyzed to determine the nature of the threat and fix the position. The information is then sent to the Fire Control System and to other vehicles through a network, (Ref. [5]). With a staring array operating at 60 Hz this process takes less than 20 ms, considerably less than the typical 1.5 s it takes to set up sufficient obscuration.

Obscurant Interference of Sensors Obscuration over a wide spectrum can be used to defeat various missile systems, including optically sighted, Semi-Active Command to Line-Of-Sight, and laser or MMW semi-active homing missiles. SACLOS missiles use a beacon facing the launcher to correct any deviations between the missile and the launcher crosshairs. Earlier designs were easily defeated by placing false beacons on the vehicle. These false beacons were much more powerful than the missile beacon and were used by the launcher to transmit false trajectory data to the missile. Improvements in missile design, by encoding the beacon signal, resulted in a missile that could not be easily jammed. Both designs are susceptible to smoke screens, as shown in Figure 11, and can still be defeated by obscuring the flight path to the vehicle. The launcher no longer sees the target vehicle and the beacon signal is scattered and absorbed by the obscurant. Obscuration will also stop designated missiles since the laser or MMW beam cannot penetrate the smoke screen. New missile designs based on hybrid seekers: Laser Semi-Active Homing and both imaging IR and MMW imagery are being developed, which will require careful manoeuvring forcing the missile to reacquire the target and correct trajectory over the distance between the vehicle and smoke screen.

Obscurants designed to interfere with threat sensors will also interfere with vehicle sensors. A sufficient downrange distance is required to use active armour successfully. Careful selection and placement smoke screens is important in providing sufficient but not excessive downrange coverage. There is probably an optimum distance at which the smoke screen should be established, which can be determined through war-gaming simulations.

Hemispherical Coverage from the Visible to MMW Range Light Armoured Vehicles will be deployed to peacekeeping environments where attacks can come from any direction. Sensors are being developed to provide the necessary hemispherical coverage but current grenade launchers, designed for Main Battle Tanks need to be redesigned to provide a similar coverage. Improving sensor technology is also increasing the spectral range of weapons from visible and infrared to millimetre wave operation.

Increased Operational Tempo Improved sensors and digital processing will automate many of the functions necessary in improving vehicle survivability. This automation with increased vehicle mobility and turret slew rate will shorten response timelines and increase operational tempo. The grenade launch velocity can be increased and the time delay shortened accordingly, but the interval between threat detection and full obscuration will still exceed 1s. During this interval, dazzling is considered to be a reasonable countermeasure since most anti-armour threats rely on an operator to aim or guide the weapon.

Automatic Configuration, Selection and Response Obscuration will be set up according to the nature and location of the threat detected. This could be carried out automatically by Defensive Aids Suite processors based on local sensors or information transmitted over a network. The grenade burst patterns would depend upon threat detection and vehicle operation, described in detail below.

Additional Launcher Requirements The current MBT launcher has a 45° launch angle, which presents several problems. Any variation in the launch velocity, usually a function of the operating temperature, results in significant variations in the burst height. At very low temperatures, grenades often hit the ground before exploding. A second problem is the excessively long time delay, often in excess of 2.5 s, required by the longer flight path. These problems can be avoided by providing additional launch tubes at a shallower angle while retaining the 45° launch tubes for fragmentation grenades. Additionally, the shallower launch angle would be more appropriate for CS gas grenades.

Obscurants, dispersed by grenades, are an effective means of protecting the LAV against weapons using sensors for targeting and guidance, (Refs. [11-15]). Successful screening materials, such as metal flake and chaff, can reduce the effectiveness of anti-armour threats operating in the visible to MMW ranges. Brass flakes, typically 2-6 μ in diameter, offers protection from visible to long-wave infrared, while chaff, consisting of aluminum coated fibres 10 mm long and 25 μ m in diameter, is useful in extending coverage into the MMW range. Small particle dimensions are essential in developing a smoke screen that will remain suspended, or persisting, for the required 30 s. Chaff dimensions, which can be relatively large to screen effectively nonetheless falls at an acceptable 0.3 m/s or 9 m in 30 s.

Each grenade contains an explosive charge, which after a suitable time delay detonates to produce a cloud of uniform density. This cloud, approximated as an 8 m sphere in this study, is

actually an oblate spheroid aligned with the axis of the grenade and controlled by the launch angle and velocity of the grenade. Since the launcher is fixed to the turret, other variables affecting the launch include: vehicle pitch, roll and speed, turret position and turret slew rate. At low operating temperatures, the launch velocity is reduced, resulting in a lower burst height. Once the initial momentum of the explosion has dissipated, atmospheric variables such as wind and turbulence distort and displace the sphere.

In peacekeeping roles, the grenade launcher will be an essential component launching a variety of grenades ranging from CS gas and illumination flares to smoke and fragmentation grenades. Unlike other platforms, land vehicles are relatively inexpensive and vulnerable to many threats, (Refs. [1-4]). These factors discourage the development of threat identification and favour a generic threat response like smoke screens. Since a grenade launcher will always be available, smoke screens will continue to play an important role in vehicle survivability.

2.3.1 Launcher calculations

A simplified governing equation including a given launcher angle, initial velocity and required launcher height can be expressed as:

$$h = h_o + V_o \sin(\alpha + \theta)t - 1/2gt^2 + V_s \sin(\alpha)t - V_o \sin(\alpha)t$$

where h is the burst height of the grenade, 4.3 m at 20° , 18.0 m at 45° and 26.7 m at 70° , h_o , is the height of the launcher, set to 2.5 m, V_o , is the initial grenade velocity, 20 and 25 m/s, α , is the vehicle incline, θ , is the launch angle (either 20° , 45° or 70°), t is the time of flight, 1.5 s, g , is acceleration due to gravity and V_s , is the vehicle velocity.

The burst pattern for the MBT, shown in Figure 6, can be improved by decreasing the grenade launch angle, increasing the launch velocity and shortening the time delay. Based on simulations, the velocity is increased to 25 m/s and the time delay is fixed at 1.5 s. Solving for the burst height, for various launch angles and vehicle incline angles, results in a family of curves shown in Figure 7. For a wide range of vehicle inclines, the 20° angle gives the most acceptable distribution of burst heights. To maintain the requirement for fragmentation grenades, the 45° angle is retained for mid-level coverage. Further protection against top-attack weapons is provided with a single grenade at 70° . A comparison between the MBT grenade system and the new LAV configuration is presented in Table 3. The total number of grenades has increased from 8 to 48 seems excessive but from previous studies, (Ref. [5]), an automated system can be made more reliable if all the components are accessible by the computer. This implies installing all the grenades in the launcher instead of stored in the vehicle. The new burst pattern configuration for the LAVs is shown in Figure 8.

2.3.2 Automated threat responses

The interval between threat detection and full obscuration will be at least 1.5 s. During this time, dazzling can be used to disrupt aiming or firing a second missile. The dazzling optics are a narrow field of view system housed in a mini-turret mounted on the main turret. Included in the

mini-turret is a laser illuminator and range-gated camera, (Ref. [16]), to actively detect various optical systems by laser illumination of the camera field of view. Based on the grenade configuration shown in Figure 8, various scenarios can be developed for further analysis. The objective is to automate the threat response as much as possible and reduce the crew work load.

Slow Moving or Stopped Vehicles In the first scenario, a threat is detected while the vehicle is stopped or moving too slowly to avoid the threat. The recommended burst pattern is shown in Figure 9. The ground screen is formed with four grenades biased towards the rear so the driver can backup while under cover. All three mid-level grenades including the 70° grenade and two aft mid-level grenades are used to counter a possible top attack. This allows the vehicle to back up and counter manoeuvre for at least 30 s. In a reasonably quiescent atmosphere, the 45° and 70° grenades should provide coverage well beyond the 30 s required.

Moving Vehicle For a moving vehicle, which is less vulnerable to sensor-fuzed submunitions, the burst pattern in Figure 10 is suggested. Both ground and mid-level grenades are used to form a series of screens, biased in the direction of vehicle travel. This procedure can be automated by launching the next set of grenades when the angle between the vehicle and the last grenade in the series approaches the angle of the threat detected. While this ensures that the vehicle remains hidden, it may still be possible to locate the vehicle by extrapolating grenade trajectories back to the launcher. If the driver, intentionally slows down or stops the vehicle, the variation of the scenario described above would be used provide protection while backing up.

2.3.3 Soft-kill system response

The response of the soft-kill system from the initial threat detection to eventual counterfire is shown in Figure 12. The detection of threats by the staring array, the time to slew the scanning optics towards the threat and the time to slew the main threat are some of the stochastic variables that influence the usefulness of dazzling as a countermeasure. As suggested by Figure 12, if the time to slew the dazzling laser into place is excessive then the advantage over launching grenades may be negligible. Dazzling can be used preemptively with the scanning optics shown in Figure 5. Automatic processing can be used to quickly detect any anomalies against the background.

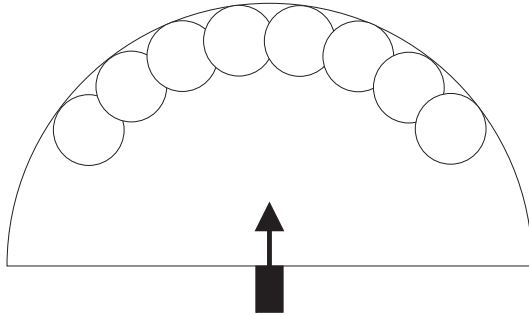

Dispersion - plan view

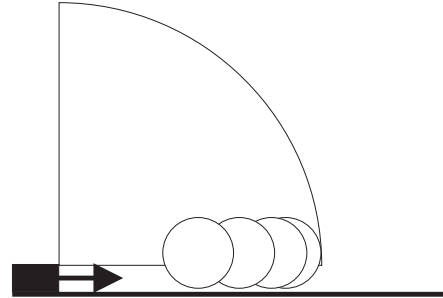

Dispersion - elevation view

Figure 6. Typical grenade-burst pattern for a Main Battle Tank. Each grenade explodes close to the ground forming 8 m diameter spheres. A total of eight grenades are launched at 45° forming a smoke screen about 45 m wide, 30 m from the vehicle. The LAVs are expected to operate in very different threat environments requiring new strategies.

Table 3. Main battle tank and light armoured vehicle grenade system parameters

PARAMETER	MAIN BATTLE TANK	LIGHT ARMoured VEHICLE
Composition Spectral coverage	Metal Flake Visible/IR	Metal Flake/Chaff Visible/IR/MMW
Time delay Burst diameter Ground screen radius	2.5 s (approx.) 8 m 30 m	1.5 s 8 m 40 m
Total number of grenades Ground level Mid level Top	8 8 launched at 44° — —	48 32 launched at 20° 12 at 44° 4 at 70°

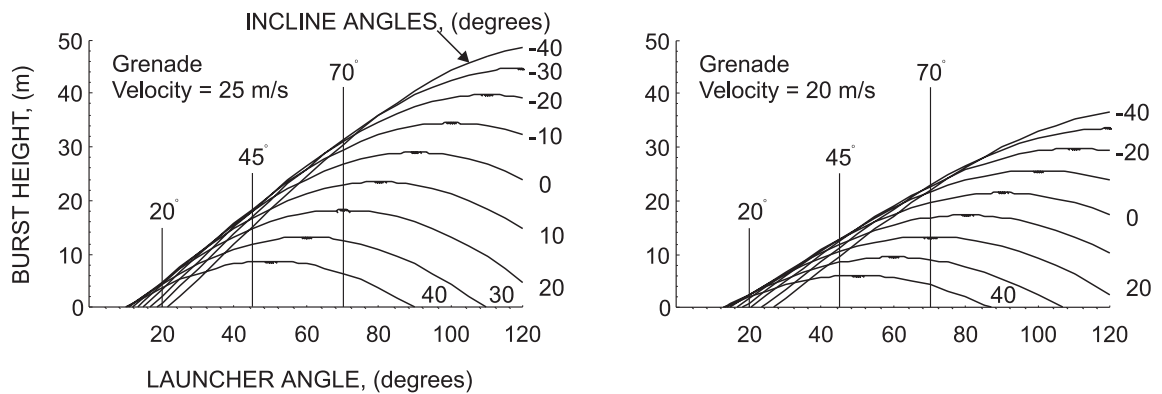

Figure 7. Solution of the launcher equation for various launcher and vehicle angles. The effects of cold-environment operations are represented by launches at 20 m/s, (right). For incline angles from -40° to 40° most grenades explode before hitting the ground. The grenade at 70° would rarely be needed unless optimum coverage is required for a stationary vehicle. Other parameters include a delay time of 1.5 s, a grenade initial velocity of 25 m/s, a vehicle forward speed of 4 m/s (14.4 km/hr) and a launcher height of 2.5 m.

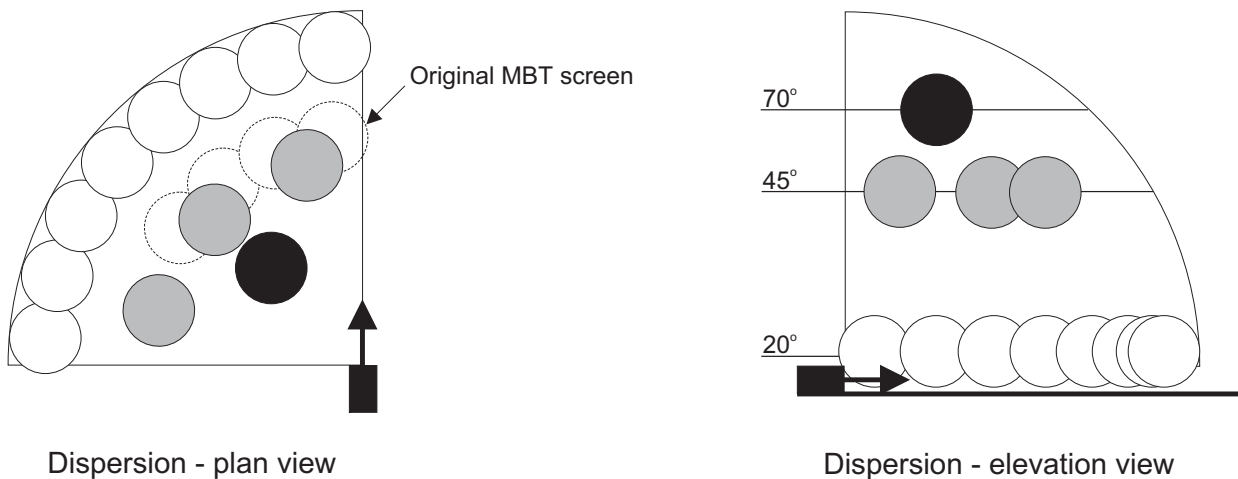

Figure 8. Typical grenade-burst pattern based on new LAV requirements, including a perimeter screen set at 40m, and for each quadrant three mid-level bursts at 45° and one at 70° . The original MBT screen for one quadrant is also shown.

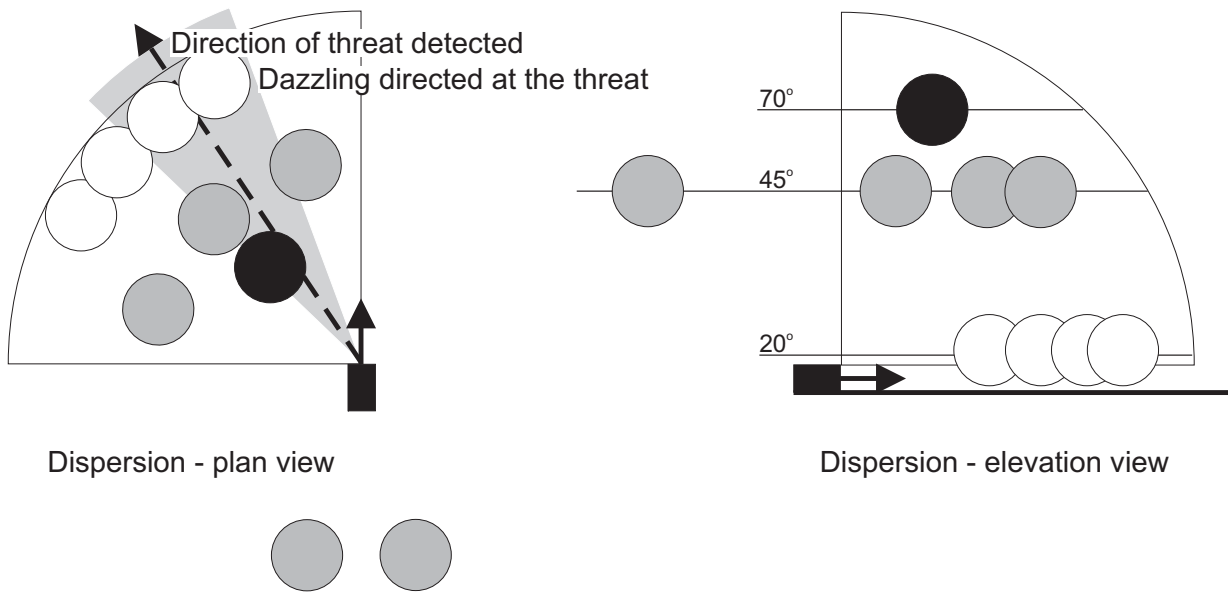

Figure 9. For slowing, stopping and backing-up manoeuvres, a perimeter screen is set up with 4 grenades, a total of 5 mid-level grenades including 2 from aft launchers are used for additional coverage. For stationary vehicles, an additional grenade can be launched at 70° to counter sensor-fuzed submunitions.

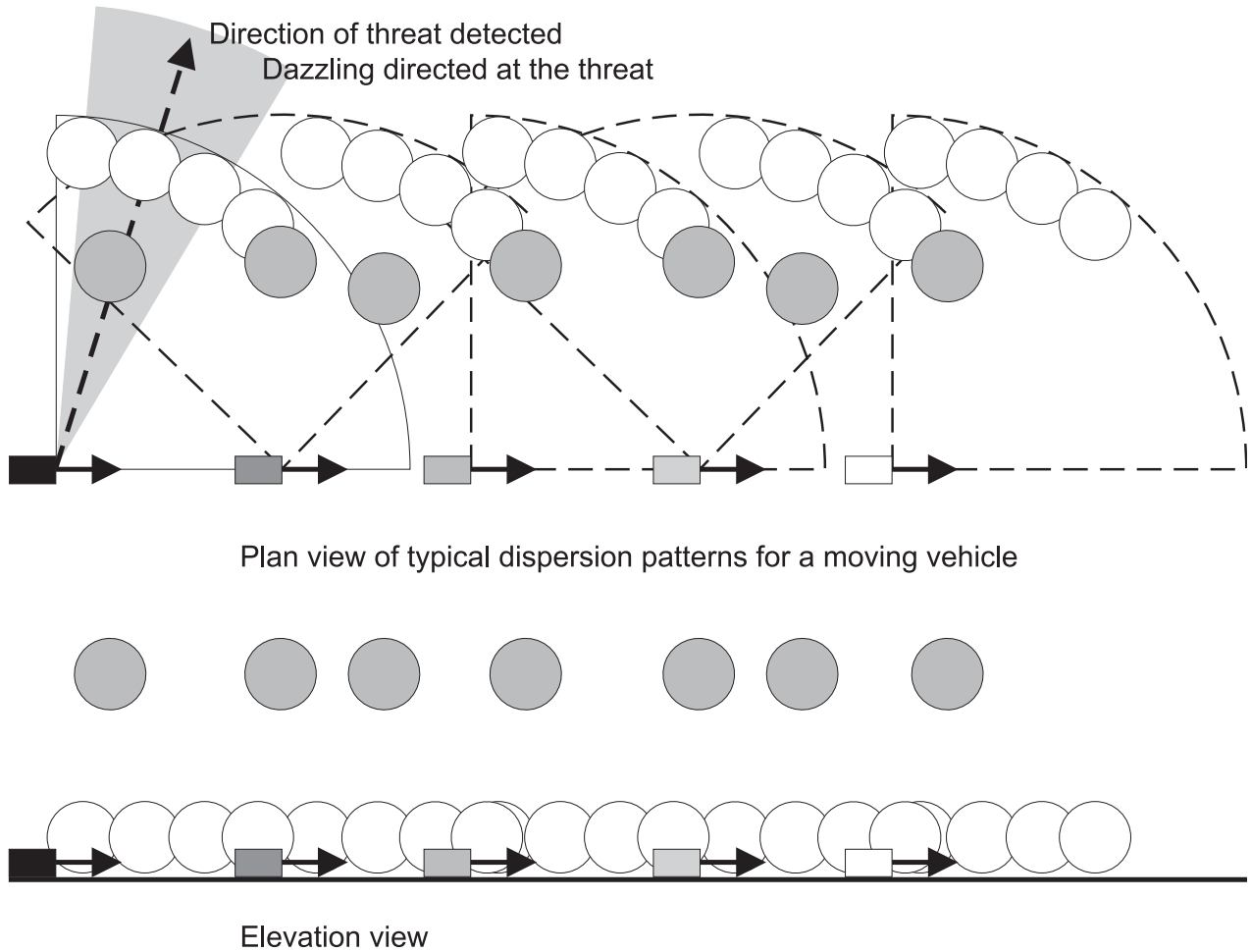

Figure 10. Typical dazdling and grenade-burst patterns, automated for a moving vehicle. Five time intervals are shown. Dazdling is used to disrupt aiming or direct fire until the screen is in place.

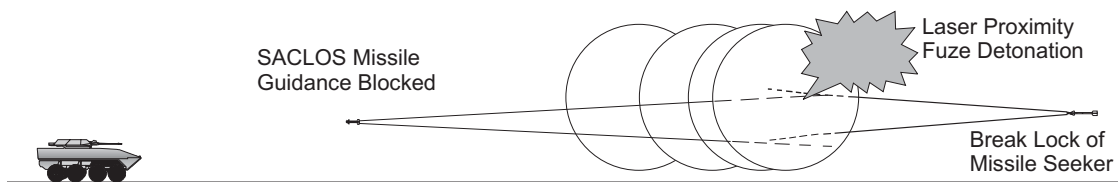

Figure 11. The LAV is protected by a screen formed by 4 grenades centered on a 36 m radius. The smoke screen blocks the signal from the SACLOS missile guidance beacon. A missile seeker, initially locked on the vehicle, breaks lock and has only 32 m to reacquire the target. Warheads using lasers to detect target surfaces can also be detonated by the metal flake cloud

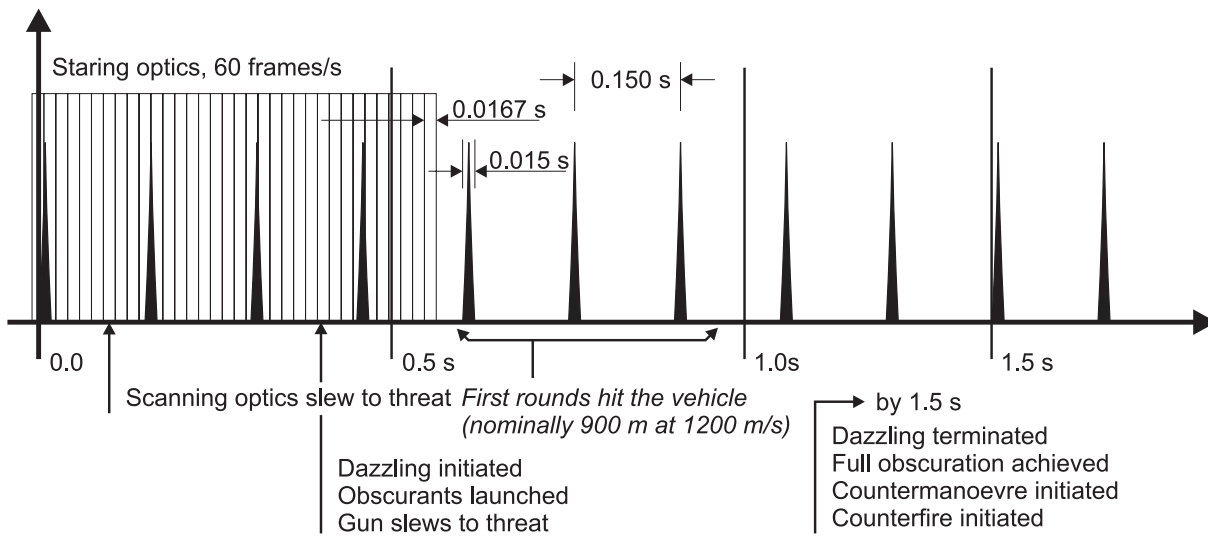

Figure 12. An automatic weapon firing 400 rounds/min is detected by the staring array. The min-turret optics slews towards the threat and a dazzling laser is activated to disrupt the gunner. At the same time, smoke grenades are launched and the main turret slews towards the threat. By 1.5 s, full obscuration is achieved and the main gun is fired using data from the Fire Control System or a Vehicle Network, if available. These events are all stochastic in nature and can be analyzed in detail using the war-gaming simulator.

3. Concluding remarks

A procedure has been outlined to improve the development of DAS technology by combining prototype development and field trials with modelling and war-gaming simulations. This new capability will provide a better estimate of vehicle performance on the battlefield and lower the cost of DAS development by including existing man-in-the-loop facilities.

A soft-kill system is defined including long-range passive optics based on available manoeuvring and targeting optical systems. The soft-kill system includes a new grenade launcher system more suited to the requirements of Light Armoured Vehicles. Vehicle networks, based on individual DAS-based LAVs, will fight better and survive longer by sharing weapons and countermeasures against potential threats. This approach of simultaneously designing a general modular DAS and direct modelling of the DAS in a war-gaming simulator is intended to meet the Army objective of configuring LAVs for specific mission requirements.

This page intentionally left blank

4. References

1. J.L. Rapanotti, A. DeMontigny, M. Palmarini and A. Cantin, "Assessing the effectiveness of defensive aids suite technology," SPIE AeroSense Conference, April 2001.
2. J.L. Rapanotti, A. DeMontigny, M. Palmarini and A. Cantin, "Developing Vehicle Survivability on a Virtual Battlefield," NATO Modelling and Simulation Group Symposium, November 2001.
3. J.L. Rapanotti, A. Cantin, and R.G. Dickinson, "Preliminary Study of Defensive Aids Suite Technology," DRDC Valcartier TM-2003-274, UNCLASSIFIED.
4. R.G. Lee, T.K. Garland-Collins, D.E. Johnson, E. Archer, C. Sparkes, G.M. Moss and A.W. Mowat, "Guided Weapons," Basseys (UK) Ltd., Third Edition 1998.
5. J.L. Rapanotti, M. Palmarini and M. Dumont, "New computer and communications environments for light armoured vehicles," SPIE AeroSense Conference, April 2002.
6. D. Harrison, "VME in the military: the M1A2 main battle tank upgrade relies on COTS VME," DY 4 Systems Inc., February 1998.
7. "Availability Features in the X500Server Family," SUN Microsystems, Inc., Technical White Paper, May 1998
8. "RioTM Architecture Overview," SUN Microsystems, Inc., Technical White Paper, May 1998
9. J.L. Rapanotti and M. Palmarini, "Dazzle and obscurant strategies for light armoured vehicles," Ground Target Modeling & Validation Thirteenth Annual Conference, August 2002.
10. P. Webb, S. Soltesz, A. Cantin, J. Fortin and D. Pomerleau, "Improved miniaturized HARLIDTM for laser warning systems having high angular resolution," SPIE AeroSense Conference, April 2001.
11. D. Sanschagrín, G. Couture, G. Roy and P. Brière, "Développement d'une grenade Fumigène de 76 mm pour véhicules blindés: correction du mouvement ascendant de l' écran fumigène," DRDC Valcartier TM-9510, SANS CLASSIFICATION.
12. G. Roy, P. Brière, D. Sanschagrín and G. Couture, "Development of a 76-mm Visual and IR Smoke Screening (VIRSS) Grenade for the Wegmann Launcher," DREV TR-9605, December 1996, UNCLASSIFIED.
13. D. Sanschagrín, "Parameters Affecting the Performance of Immediate Screening Smoke for Armoured Fighting Vehicle Protection," DREV TM-9829, December 1999, UNCLASSIFIED.
14. D. Sanschagrín, "Effect of the Bulk Density of a Brass Flake Obscurant on the Dissemination of an Explosive Smoke Device (U)," DREV TM-9836, December 1999, PROTECTED B.

15. D. Sanschagrin, P. Brière and J. Dumas, "Preliminary Field Trial of the Advanced Development Model of the 76-mm VIRSS Grenade (U)," DREV TM-9837, December 1999, PROTECTED B.
16. V. Larochelle, D. Bonnier, D. Dubé, G. Tardif and J. Bédard, "Optical Detection of Snipers Using Albedos: November 95 Trial (U)," DREV TR-9625, June 1997, CONFIDENTIAL.

Annex A: Vetronics and networking

Vetronics is an important and complex subject dealing with many aspects of LAV performance. To keep the investigation more tractable our interest is limited to computer and communications technologies available to the vehicle designer from the present to 2015.

The following chapters will investigate how these features will be implemented or developed further, including the networking of the vehicles.

Current systems

A typical system based on current technology could include:

- Real-Time Operating System (RTOS) such as Wind River Systems VxWorks[®],
- PowerPC[®] CPU,
- VMEBus architecture and
- dual Mil-Std 1553B serial communication

The typical performance of these components is shown in Table A1.

Table A1. Current computer and communications characteristics

REQUIREMENT	SYSTEM	PERFORMANCE
Computer architecture	VMEbus	320 MByte/s
Operating System , event driven, low latency high availability	Wind River Systems, VxWorks LinuxWorks [™] , LynxOS [®]	RTOS, supported RTOS, POSIX compliance
Processor	IBM PowerPC 604e <i>Compaq Alpha 21264a</i>	64-bit, 333 MHz 14.7 SpecFP95 64-bit, 700 MHz 54.5 SpecFP95
Serial communication protocol	MIL-STD-1553B Notice II	1 Mbit/s

The obvious limitation is in the transmission rate of the MIL-STD-1553B standard which at 1 Mb/s is not taking advantage of the processing capacity of the PowerPC . This limitation and the additional capabilities possible are addressed in the chapter below.

Future systems

Future vehicles can be configured into networks with an emphasis on the following technologies:

- ISTAR network, for integration of all battlefield asset including command and control
- Jini™ layer/Rio™ integration, for seamless integration of vehicles into a platoon
- RTOS with Java™ capability, exemplified by the two systems below
 - VxWorks AE by Wind River Systems
 - LynxOS by LynuxWorks
- computer architecture, for high performance meeting military requirements
 - VMEBus
 - CompactPCI
- High Availability vetronics
 - Alternate Pathing to multiple components
 - Dynamic Reconfiguration
 - “Hot swappable”
 - “Hot pluggable”
 - Fiber Channel serial communication

The performance of these features is shown in Table A2 and chapters below. The service, Fibre Channel Class 1, describes a dedicated connection between two node ports communicating at the full bandwidth transmission rate and free of interference from other network traffic. This level of performance would be appropriate for continuous, time-critical data such as data transfer from infrared imaging arrays. This data would be transferred to a processor and combined with events detected by lower resolution sensors, such as radar, laser warning detectors and ultraviolet imagers, depicted in Figure 5. A real-time operating system would respond quickly to threat events, locate the group of pixels indicated by the sensors and analyze that area with threat detection algorithms. The threat would be identified and the necessary countermeasure solutions determined.

Table A2. Future computer and communications characteristics

REQUIREMENT	SYSTEM	PERFORMANCE
Computer architecture	VMEbus CompactPCI	2000 MByte/s 2000 MByte/s
Operating System , event driven, low latency high availability, fault tolerant	Wind River Systems, VxWorks AE LynuxWorks , LynxOS	RTOS, supported RTOS, POSIX compliance
Processor	IBM PowerPC	64-bit, 700 MHz 27.7 SpecFP95
Serial communication protocol	Fibre Channel, optical fibre	400 MByte/s

High Availability (HA) principles are being used to develop reliable computer systems in critical applications and will probably influence the development of DAS. The high level of reliability and transparency to the user will make the DAS much easier to accept.

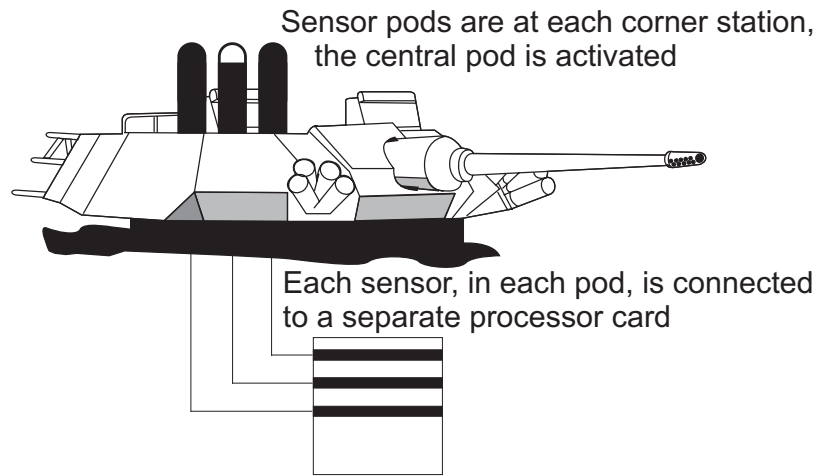

Figure A1. A typical turret with three sensor pods at a turret corner station. Two pods are on standby and protected from damage. For maximum reliability each sensor, in each pod, is connected to a separate processor card.

Alternate or Redundant Paths to Sensors: The sensors are assumed to be distributed over the vehicle turret and not configured as a single pod. A possible solution is assemble the sensors into pods, combining several pods to form a station which would be placed at each corner of the turret, as shown in Figure A1. For maximum reliability, each sensor would be connected to a separate processor board.

Dynamic Reconfiguration of the System: The operating system must be capable of detecting the loss of a particular sensor or sensors and switch seamlessly to the other available sensors or sensor pods. Replacement of the sensors and other components is also possible while the operating system is still running through “hot plug” and “hot swap” technology.

Dynamic Attachment: This is the process of logically attaching components, such as a new sensor pod, to the operating system that are already attached physically.

Dynamic Detachment: The process of logically detaching components from the operating system.

Hot Pluggable: The sensors would be connected physically with optical fibre, following the Fibre Channel standard, but electronic components can also be added or removed without disrupting the operating system.

Hot Swappable: This is the ability to add or remove components from the operation system without notification. The new component is recognized automatically. This approach would be useful when adding or replacing grenades.

The operating system is critical in the development of High Availability systems. Both VxWorks AE, by Wind River Systems, and LynxOS, by LynxWorks, have many of these features. VxWorks AE is described as a RTOS with HA features including: Reliability, Availability, Serviceability, and Security (RASS).

Many of the problems that arise in the integration of vehicles have been addressed in the development of Distributed Computing. Tasks, such as reacting to a threat, can be treated as a set of processes that are distributed across a network of vehicles.

The advantages of using a distributed system include:

Performance: it is much more difficult to defeat a network of vehicles than defeating individual vehicles. For example, one vehicle may detect the threat but the entire platoon can respond to it.

Scalability: by designing applications to work over a number of processors, the application becomes scalable. If the processing load becomes too much for the team of computers, another is simply added without having to redesign the application.

Resource sharing: remote access to weapons and countermeasures can be supported and coordinated.

Fault tolerance and availability: distributed systems can tolerate certain amounts of failure since they are built from multiple, independent processes. If one process fails, others can continue.

Some of the issues that arise when developing a distributed system include:

Latency: or lag time, as processes, in an effort to collaborate, try to communicate over networks.

Synchronization: of processes over the network while operating independently.

Partial failure: a distributed system must be able to adapt when confronted with one or more of the components failure.

Jini is a simple set of Java classes (Application Programming Interfaces) and services within a distributed computing framework. It allows cooperating devices, services, and applications to access each other seamlessly, to adapt to a dynamic environment, and to share code and configurations transparently.

Jini is a set of specifications that enables services to find each other on a network and allows these services to participate within certain types of operations within the framework. This set of services on a specified network assumes that all hardware and software is a service. Jini allows these services to interact in a dynamic and robust way without attention from the operator when assets on the network must be added or removed. A lookup service runs on the Jini network which maintains a list of all the services available on the network. Services can come and go without affecting the network adversely and without requiring user intervention.

Jini can be used to integrate vehicles seamlessly into a network where weapons and countermeasures can be shared effectively and threat detection can be communicated to the entire network without excessive intervention required from the crews.

The Rio architecture is an extension of the Jini layer technology with an emphasis on the following capabilities:

- Dynamically adapt to addition and removal of assets on the network.
- Optimize the use of available resources, for example counterfire, based on requirements.
- Dynamically reconfiguration in response to a failure on the network.
- Provide infrastructure and tools required to measure, monitor and scale distributed service assets.

Glossary

Alternate Pathing provides redundancy in the event of a component failure by providing alternate, redundant systems.

API Application Programming Interface: The specification of how a programmer writing an application accesses the behavior and state of classes and objects.

class In the Java programming language, a type that defines the implementation of a particular kind of object.

CompactPCI architecture cPCI, a competitor of VMEBus architecture, developed by the telecommunications industry.

Distributed Computing is computing based on distinct components running in separate runtime environments, usually on different platforms connected by a network.

Dynamic Reconfiguration software enables changes to a system hardware resources, such as when there is a component failure, while the system is up and running, without a system reboot.

Fiber Channel is a computer communications protocol designed to meet the demands of high performance information transfer. Fiber Channel devices may use both the channel protocol Small Computer System Interface (SCSI) and the Internet Protocol (IP).

High Availability, HA, is a software and hardware approach based on redundancy and fault tolerance to improve reliability in computer systems.

jammer based on a wide range of designs, introduces noise into the missile guidance feedback circuitry.

JavaSpacesTM is a technology that provides distributed persistence and data exchange mechanisms for code in the Java programming language.

Java is a set of technologies for creating and running software programs in both stand-alone and networked environments.

Jini Technology is a set Jini APIs that enable transparent networking of devices and services and eliminates the need for system or network administration intervention by a user.

LI/RG camera is a camera with variable gate control to improve detection by illuminating a target with a pulsed laser.

Mil-Std 1553B is a digital data bus designed to replace analog point-to-point wire bundles between electronic instrumentation. The latest version of the serial local area network (LAN) for military avionics known as MIL-STD-1553B was issued in 1978.

object Each object is a programming unit consisting of data and functionality.

POSIX compliance is a Portable Operating System Interface, standardized by ISO/IEC, IEEE and The Open Group.

PowerPC a CPU produced by IBM, Motorola and Apple, preferred for embedded and military applications.

Quality of Service is a Rio feature emphasizing an optimum use of resources.

Rio architecture introduces concepts and capabilities that extend Jini into the areas of Quality of Service, Dynamic Deployment, Fault Detection and Recovery.

RTOS a Real-Time Operating System is characterized by low latency to triggering events, thereby providing an immediate response.

SpecFP95 a measure of CPU floating point performance through an objective series of tests, produced by the SPEC Open Systems Steering Committee, which can serve as common reference and be considered as part of an evaluation process.

VMEBus architecture the most popular computer architecture in military applications.

This page intentionally left blank

Distribution list

- 1 – Director General
- 1 – Head Electro-Optical Warfare
- 1 – Head Precision Weapons
- 1 – Head Energetic Materials
- 3 – Document Library
- 1 – Dr. J.L. Rapanotti (author)
- 1 – Mr. G. Pelletier
- 1 – Mr. E. Thibeault
- 1 – Dr. J. Fortin

External

- 1 – DRDKIM (.pdf copy)

- 1 – Mr. Davis Saint
 - DSTL 5
 - National Defence Headquarters, 12 NT
 - 101 Colonel By Drive
 - Ottawa, ON, K1A 0K2

- 1 – Head FFSE
 - DRDC Ottawa
 - 3701 Carling Avenue
 - Ottawa ON, K1A 0Z4

- 1 – DLR 2-5
 - National Defence Headquarters, 12 NT
 - 101 Colonel By Drive
 - Ottawa, ON, K1A 0K2

- 1 – LCol Luc Petit
 - DLR 3
 - LSTL 1st Floor SE 02
 - 555 blvd de la Carrière
 - Gatineau QC, K1A 0K2

- 1 – Capt. Mark McNeil
 - DLR 3-3 LSTL
 - 1st Floor SE 02

555 blvd de la Carrière
Gatineau QC, K1A 0K2

- 1 – Director DLSC
Fort Frontenac
PO Box 17000, Stn Forces
Kingston, ON, K7B 7B4

- 1 – Dr. Paul A. Roman
Army Synthetic Environment Coordination Office
Army Simulation Centre
PO Box 17000, Stn Forces
Kingston, ON, K7B 7B4

- 1 – J2 DSI 7-3
National Defence Headquarters
101 Colonel By Drive
Ottawa, ON, K1A 0K2

- 1 – J2 DSI 7-3-2 ATGM
National Defence Headquarters
101 Colonel By Drive
Ottawa, ON, K1A 0K2

- 1 – Maj. Gordon Fisher
J2 DSI 7-4
National Defence Headquarters
101 Colonel By Drive
Ottawa, ON, K1A 0K2

1 – Maj. Luc Nadon
J2 DSI 7-4-4
National Defence Headquarters
101 Colonel By Drive
Ottawa, ON, K1A 0K2

1 – Maj. Michel Lavallé
RWGT
National Defence Headquarters, 6 CBS
101 Colonel By Drive
Ottawa, ON, K1A 0K2

1 – Maj. Les Mader
Land Staff Secretariat
Decision Support Cell
National Defence Headquarters, 12 NT
101 Colonel By Drive
Ottawa, ON, K1A 0K2

This page intentionally left blank

UNCLASSIFIED
SECURITY CLASSIFICATION OF FORM
(Highest Classification of Title, Abstract, Keywords)

DOCUMENT CONTROL DATA		
1. ORIGINATOR (name and address) Dr. John Rapanotti DRDC Valcartier	2. SECURITY CLASSIFICATION (Including special warning terms if applicable) Unclassified	
3. TITLE (Its classification should be indicated by the appropriate abbreviation (S, C, R or U) Developing soft-kill capability for light armoured vehicles through battlefield simulations (U)		
4. AUTHORS (Last name, first name, middle initial. If military, show rank, e.g. Doe, Maj. John E.) Rapanotti John L.		
5. DATE OF PUBLICATION (month and year) February 2007	6a. NO. OF PAGES 50	6b. NO. OF REFERENCES 16
7. DESCRIPTIVE NOTES (the category of the document, e.g. technical report, technical note or memorandum. Give the inclusive dates when a specific reporting period is covered.) Memorandum, January 2002 - December 2003		
8. SPONSORING ACTIVITY (name and address) DLR, DND		
9a. PROJECT OR GRANT NO. (Please specify whether project or grant) 2fi16	9b. CONTRACT NO.	
10a. ORIGINATOR'S DOCUMENT NUMBER TM 2003-276	10b. OTHER DOCUMENT NOS N/A	
11. DOCUMENT AVAILABILITY (any limitations on further dissemination of the document, other than those imposed by security classification)		
<input checked="" type="checkbox"/> Unlimited distribution <input type="checkbox"/> Restricted to contractors in approved countries (specify) <input type="checkbox"/> Restricted to Canadian contractors (with need-to-know) <input type="checkbox"/> Restricted to Government (with need-to-know) <input type="checkbox"/> Restricted to Defense departments <input type="checkbox"/> Others		
12. DOCUMENT ANNOUNCEMENT (any limitation to the bibliographic announcement of this document. This will normally correspond to the Document Availability (11). However, where further distribution (beyond the audience specified in 11) is possible, a wider announcement audience may be selected.)		

UNCLASSIFIED
SECURITY CLASSIFICATION OF FORM
(Highest Classification of Title, Abstract, Keywords)

UNCLASSIFIED
SECURITY CLASSIFICATION OF FORM
(Highest Classification of Title, Abstract, Keywords)

13. ABSTRACT (a brief and factual summary of the document. It may also appear elsewhere in the body of the document itself. It is highly desirable that the abstract of classified documents be unclassified. Each paragraph of the abstract shall begin with an indication of the security classification of the information in the paragraph (unless the document itself is unclassified) represented as (S), (C), (R), or (U). It is not necessary to include here abstracts in both official languages unless the text is bilingual).

Light Armoured Vehicles (LAVs) are being developed to meet the modern requirements of rapid deployment and operations other than war. To achieve these requirements, passive armour is minimized and survivability depends more on a soft-kill capacity including sensors, computers, countermeasures and communications to detect and avoid threats. Sensors for these soft-kill systems are passive, to avoid being detected, and therefore can be used to detect threats at much longer ranges. Battlefield obscuration strategies, optimized for Main Battle Tanks in traditional high intensity conflicts, are inadequate when applied to LAVs. LAVs are vulnerable to many threats and sufficiently different in design, capability and battlefield environment to benefit significantly from new strategies. Factors influencing this requirement include: i)-the development of sensors with increasing accuracy and precision, ii)-the need to minimize obscurant interference with vehicle sensors and other countermeasures, including active armour and explosive reactive armour, iii)-the need to develop hemispherical obscurant coverage extending into the millimetre wave range, iv)-grenades are needed to better match the increased tempo from greater vehicle speed, mobility and turret slew rate, v)-the automatic configuration and selection of grenade burst patterns based on on-board processing and vehicle networks.

Spectral coverage in the visible to long-wave infrared regions is adequate, but trends in missile design are leading to the development of hybrid seekers including, laser designating, MMW seeking and imaging-infrared seeking capability accelerated by MEMS technology. With increased tempo, the time needed to achieve full obscuration becomes critical. Dazzling of a detected threat can be used to disrupt aiming and firing a second missile until full obscuration is achieved. Dazzling can also be used with the laser-illumination detection of optical systems. A generic threat response, based on dazzling and visible/IR/MMW grenades is preferred because of the large number of possible threats and the difficulty in developing practical identification strategies.

New dazzling and obscuration strategies, based on extensive knowledge acquired through field trials, will be analyzed and developed using ModSAF. These new strategies and the approach used to develop them will be discussed in the memorandum. The impact these technologies will have on LAV vetronics is also discussed in Appendix A.

14. KEYWORDS, DESCRIPTORS or IDENTIFIERS (technically meaningful terms or short phrases that characterize a document and could be helpful in cataloguing the document. They should be selected so that no security classification is required. Identifiers, such as equipment model designation, trade name, military project code name, geographic location may also be included. If possible keywords should be selected from a published thesaurus, e.g. Thesaurus of Engineering and Scientific Terms (TEST) and that thesaurus-identified. If it is not possible to select indexing terms which are Unclassified, the classification of each should be indicated as with the title.)

Light Armoured Vehicle,
Defensive Aids Suite,
ModSAF,
Operations Other Than War,
peacekeeping

UNCLASSIFIED
SECURITY CLASSIFICATION OF FORM
(Highest Classification of Title, Abstract, Keywords)

Defence R&D Canada

Canada's Leader in Defence
and National Security
Science and Technology

R & D pour la défense Canada

Chef de file au Canada en matière
de science et de technologie pour
la défense et la sécurité nationale



WWW.drdc-rddc.gc.ca

